



NordicTrack®

X5i Incline Trainer USER'S MANUAL



Model No. NTL15909.3

Serial No. _____

Write the serial number here (see page 6).

CAUTION

Read all precautions and instructions in this manual before using this equipment. Save this manual for future reference.

QUESTIONS?

If you have questions, or if parts are damaged or missing, **DO NOT CONTACT THE STORE;** please contact Customer Care.

IMPORTANT: To help us assist you, please register this product (see the limited warranty on page 34) before contacting Customer Care.

CALL: **1-800-TO-BE-FIT** (1-800-862-3348) M-F 6 a.m.–6 p.m. MT; Sat. 8 a.m.–4 p.m. MT
ON THE WEB: www.nordictrackservice.com

TABLE OF CONTENTS

WARNING DECAL PLACEMENT3
 IMPORTANT PRECAUTIONS4
 BEFORE YOU BEGIN6
 ASSEMBLY7
 OPERATION AND ADJUSTMENT14
 HOW TO MOVE THE INCLINE TRAINER22
 TROUBLESHOOTING23
 EXERCISE GUIDELINES26
 PART LIST27
 EXPLODED DRAWING29
 ORDERING REPLACEMENT PARTS33
 LIMITED WARRANTY34

WARNING DECAL PLACEMENT

This drawing shows the locations of the warning decals. **If a decal is missing or illegible, call the telephone number on the front cover of this manual and request a free replacement decal. Apply the decal in the location shown.** Note: The decals may not be shown at actual size.

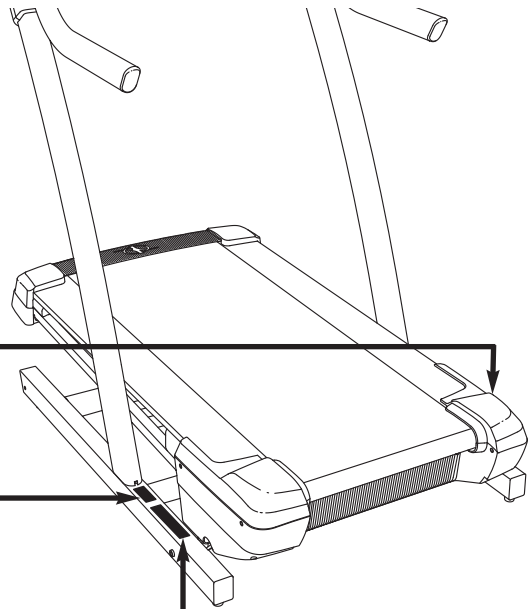

⚠ CAUTION
 KEEP HANDS AND FEET AWAY FROM THIS AREA WHILE THE TREADMILL IS IN OPERATION.

⚠ WARNING: Protect yourself and others from risk of serious injury. Read the user's manual or obtain proper instruction before use and:

- Stand only on side rails when starting or stopping treadmill.
- Change speed in small increments.
- Hold handrails to prevent falling, and always wear the safety clip while operating treadmill.
- Stop if you feel faint, dizzy, or short of breath.
- Never allow children on or around treadmill.
- Remove key when not in use.
- Keep clothing, fingers, and hair away from moving belt.
- Never try to adjust or fix the belt while it is moving.
- Always wear athletic shoes while operating treadmill.

IMPORTANT PRECAUTIONS

⚠️ WARNING: To reduce the risk of serious injury, read all important precautions and instructions in this manual and all warnings on your incline trainer before using your incline trainer. ICON assumes no responsibility for personal injury or property damage sustained by or through the use of this product.

1. Before beginning this or any exercise program, consult your physician. This is especially important for persons over age 35 or persons with pre-existing health problems.
2. It is the responsibility of the owner to ensure that all users of this incline trainer are adequately informed of all warnings and precautions.
3. Use the incline trainer only as described.
4. Keep the incline trainer indoors, away from moisture and dust. Do not put the incline trainer in a garage or covered patio, or near water.
5. Place the incline trainer on a level surface, with at least 8 ft. (2.4 m) of clearance behind it and 2 ft. (0.6 m) on each side. Do not place the incline trainer on any surface that blocks air openings. To protect the floor or carpet from damage, place a mat under the incline trainer.
6. Do not operate the incline trainer where aerosol products are used or where oxygen is being administered.
7. Keep children under age 12 and pets away from the incline trainer at all times.
8. The incline trainer should be used only by persons weighing 300 lbs. (136 kg) or less.
9. Never allow more than one person on the incline trainer at a time.
10. Wear appropriate exercise clothes when using the incline trainer. Do not wear loose clothes that could become caught in the incline trainer. Athletic support clothes are recommended for both men and women. *Always wear athletic shoes. Never use the incline trainer with bare feet, wearing only stockings, or in sandals.*
11. When connecting the power cord (see page 14), plug the power cord into a surge suppressor (not included) and plug the surge suppressor into a grounded circuit capable of carrying 15 or more amps. No other appliance should be on the same circuit. Do not use an extension cord.
12. Use only a single-outlet surge suppressor that meets all of the specifications described on page 14. To purchase a surge suppressor, see your local NordicTrack dealer or call the telephone number on the front cover of this manual and order part number 146148, or see your local electronics store.
13. Failure to use a properly functioning surge suppressor could result in damage to the control system of the incline trainer. If the control system is damaged, the walking belt may slow, accelerate, or stop unexpectedly, which may result in a fall and serious injury.
14. Keep the power cord and the surge suppressor away from heated surfaces.
15. Never move the walking belt while the power is turned off. Do not operate the incline trainer if the power cord or plug is damaged, or if the incline trainer is not working properly. (See TROUBLESHOOTING on page 23 if the incline trainer is not working properly.)
16. Read, understand, and test the emergency stop procedure before using the incline trainer (see HOW TO TURN ON THE POWER on page 16).
17. Never start the incline trainer while you are standing on the walking belt. Always hold the handrails while using the incline trainer.

18. The incline trainer is capable of high speeds. Adjust the speed in small increments to avoid sudden jumps in speed.
19. The pulse sensor is not a medical device. Various factors, including the user's movement, may affect the accuracy of heart rate readings. The pulse sensor is intended only as an exercise aid in determining heart rate trends in general.
20. Never leave the incline trainer unattended while it is running. Always remove the key, unplug the power cord, and press the power switch into the off position when the incline trainer is not in use. (See the drawing on page 6 for the location of the power switch.)
21. Do not attempt to move the incline trainer until it is properly assembled. (See ASSEMBLY on page 7, and HOW TO MOVE THE INCLINE TRAINER on page 22.) You must be able to safely lift 45 lbs. (20 kg) to move the incline trainer.
22. Do not change the incline of the incline trainer by placing objects under the incline trainer.
23. Inspect and properly tighten all parts of the incline trainer regularly.
24. Never insert or drop any object into any opening on the incline trainer.
25. **DANGER:** Always unplug the power cord immediately after use, before cleaning the incline trainer, and before performing the maintenance and adjustment procedures described in this manual. Never remove the motor hood unless instructed to do so by an authorized service representative. Servicing other than the procedures in this manual should be performed by an authorized service representative only.
26. The incline trainer is intended for in-home use only. Do not use the incline trainer in any commercial, rental, or institutional setting.
27. Over exercising may result in serious injury or death. If you feel faint or if you experience pain while exercising, stop immediately and cool down.

SAVE THESE INSTRUCTIONS

BEFORE YOU BEGIN

Thank you for selecting the revolutionary NordicTrack® INCLINE TRAINER X5i INTERACTIVE. The INCLINE TRAINER X5i INTERACTIVE offers a selection of features designed to make your workouts at home more enjoyable and effective.

For your benefit, read this manual carefully before using the incline trainer. If you have questions after reading this manual, please see the front cover of this

manual. To help us assist you, note the product model number and serial number before contacting us. The model number is shown on the front cover of this manual. The location of the serial number decal is shown below.

Before reading further, please familiarize yourself with the parts that are labeled in the drawing below.

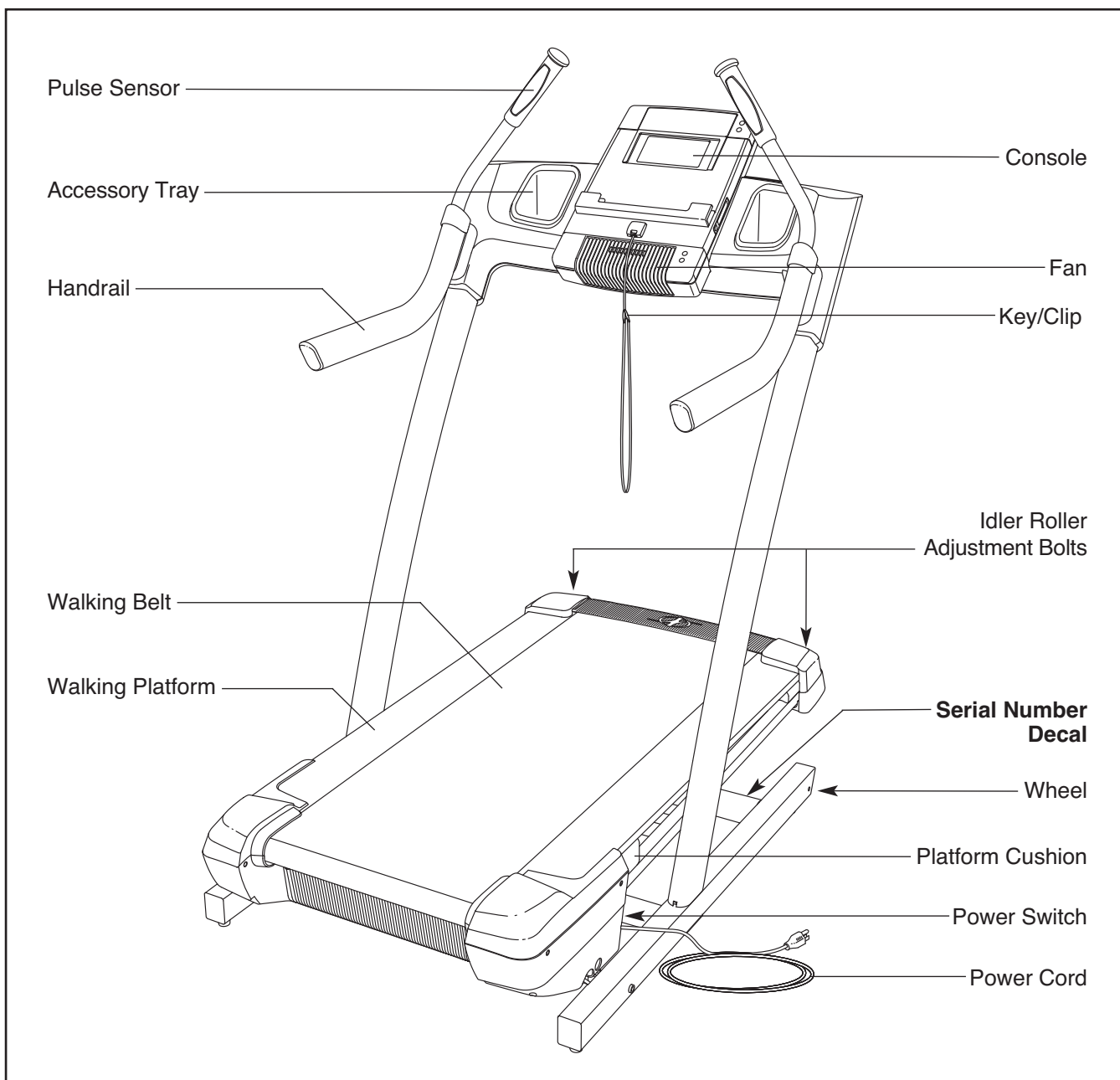

ASSEMBLY

Assembly requires two persons. Set the incline trainer in a cleared area and remove all packing materials. **Do not dispose of the packing materials until assembly is completed.** Note: The underside of the incline trainer walking belt is coated with high-performance lubricant. During shipping, some lubricant may be transferred to the top of the walking belt or the shipping carton. This is normal and does not affect incline trainer performance. If there is lubricant on top of the walking belt, simply wipe off the lubricant with a soft cloth and a mild, non-abrasive cleaner.

Assembly requires the included hex keys  and your own Phillips screwdriver .

Use the drawings below to identify the assembly hardware. The number in parentheses below each drawing is the key number of the part, from the PART LIST near the end of this manual. The number after the parentheses is the quantity needed for assembly. **Note: Some small parts may have been preassembled. To avoid damaging parts, do not use power tools for assembly. Extra hardware may be included.**

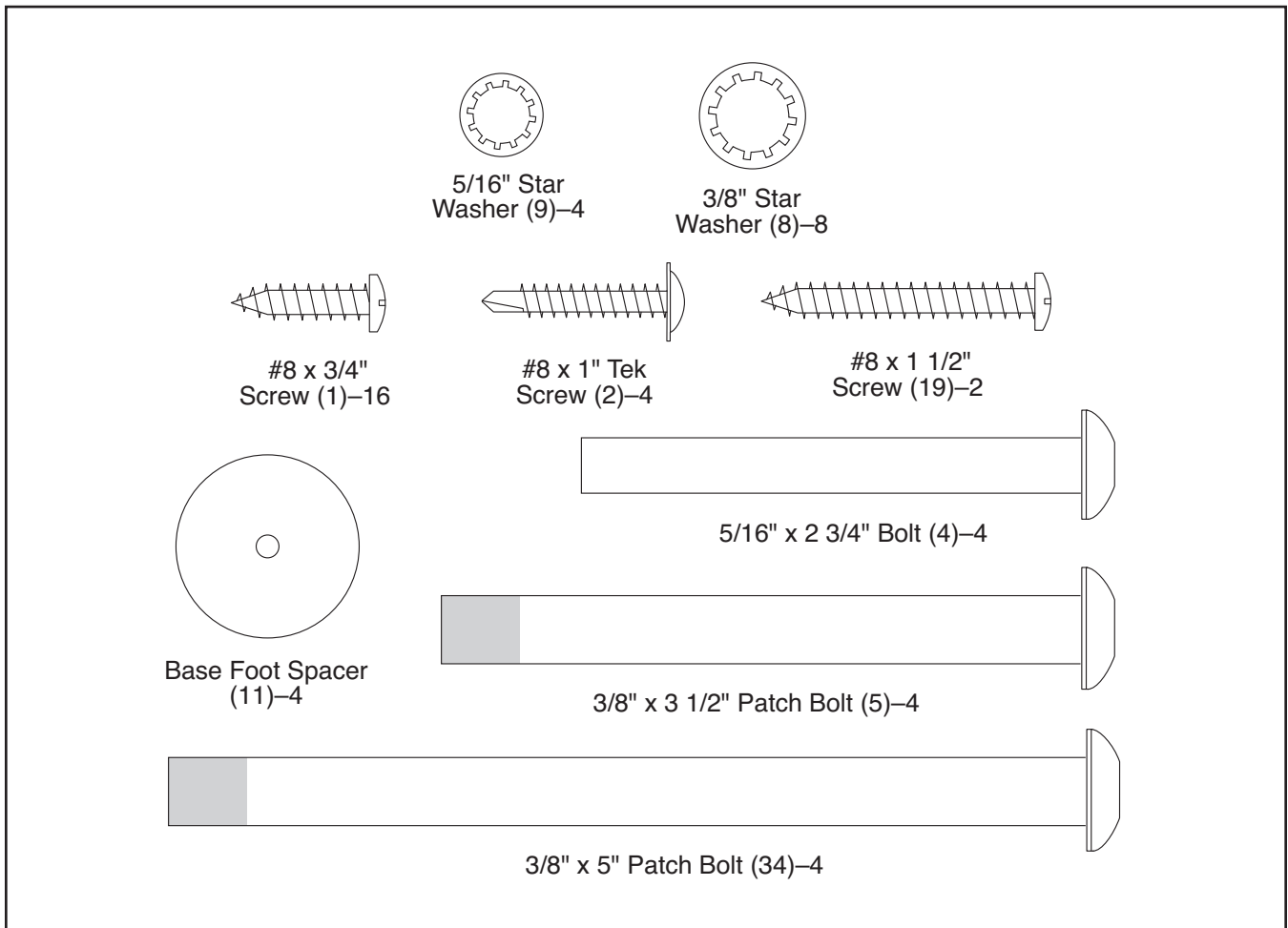

1. **Make sure that the power cord is unplugged.**

With the help of a second person, tip the incline trainer onto its left side. **Have the second person hold the incline trainer to prevent it from falling.**

Attach four Base Feet (10) and four Base Foot Spacers (11) to the Base (80) with four #8 x 1" Tek Screws (2) in the locations shown. **Be careful not to overtighten the Tek Screws.**

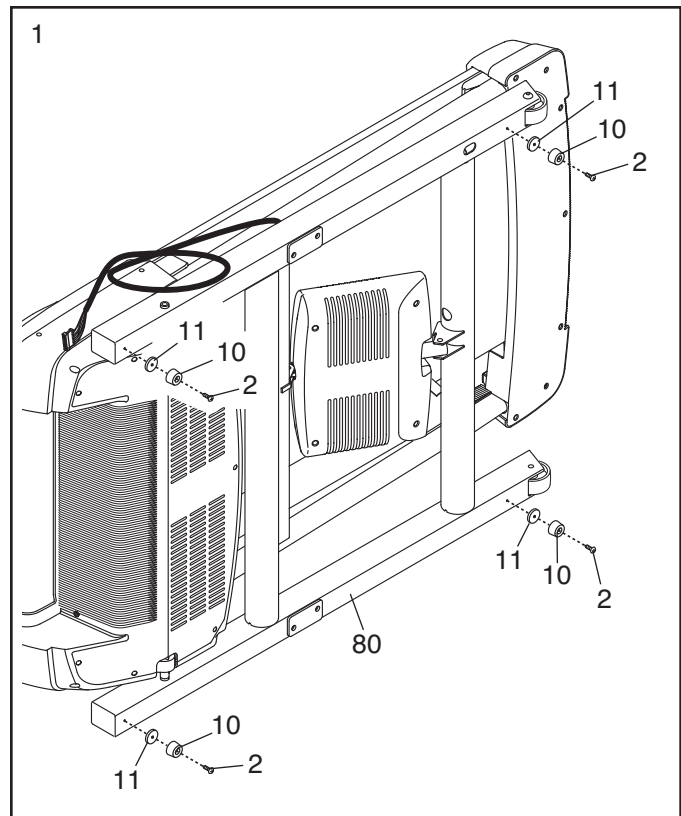

2. Identify the Right Upright (79), which is marked with a "Right" sticker. Hold the Right Upright near the incline trainer.

See the lower inset drawing. Tie the wire tie in the Right Upright (79) around the end of the Upright Wire (78). **See the upper inset drawing.** Then, pull the other end of the wire tie until the Upright Wire is routed out of the side hole near the top of the Right Upright.

Orient the Right Upright (79) as shown. Attach the Right Upright to the Base (80) with two 3/8" x 3 1/2" Patch Bolts (5) and two 3/8" Star Washers (8). **Start both Patch Bolts, and then tighten each of them. Be careful not to pinch the Upright Wire (78).**

With the help of a second person, tip the incline trainer onto its right side. **Have the second person hold the incline trainer to prevent it from tipping.**

Attach the Left Upright (not shown) as described above. Note: There are no wires on the left side.

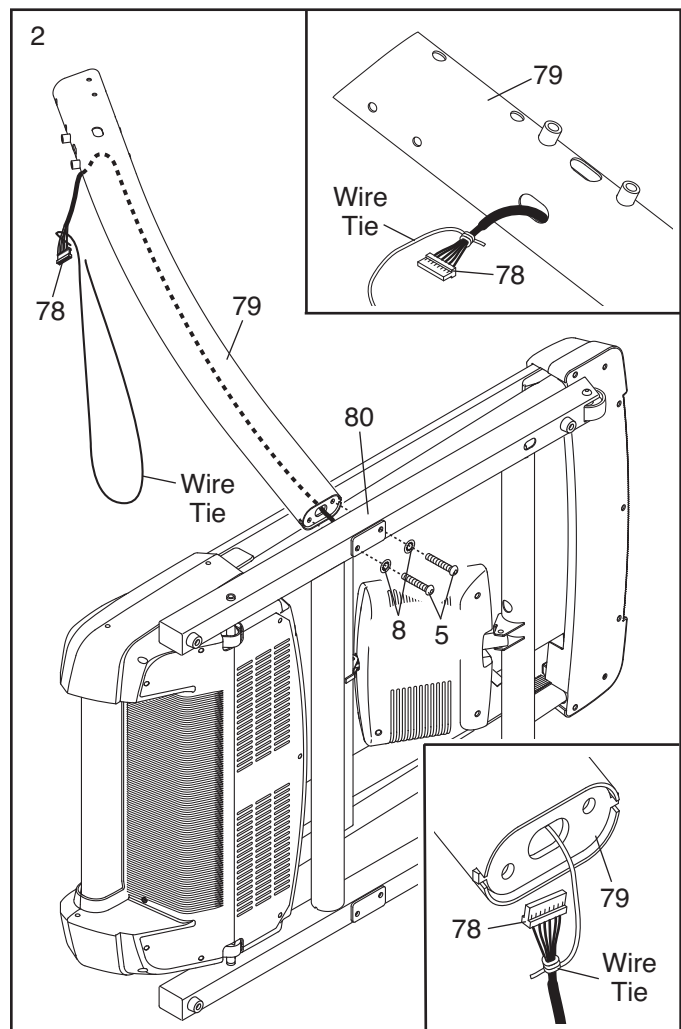

3. With the help of a second person, carefully tip the incline trainer down so that the Base (80) is flat on the floor.

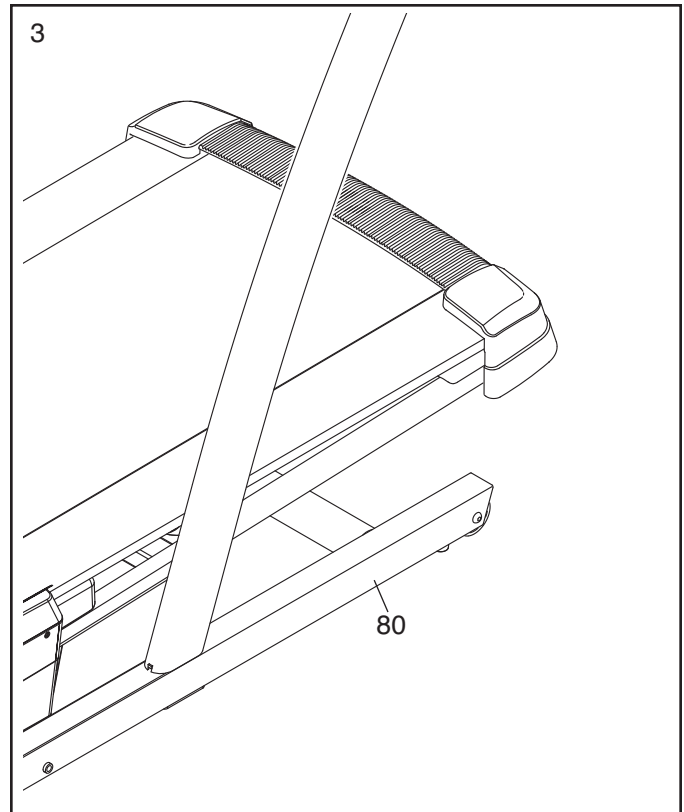

4. Set the Console Cover (87) face down on a soft surface. Remove the two #8 x 1 1/2" Screws (19) from the Console Back (89). **Save the Screws for step 6.**

Separate the Console Back (89) from the Console Cover (87), and remove the Console Crossbar (not shown) from inside.

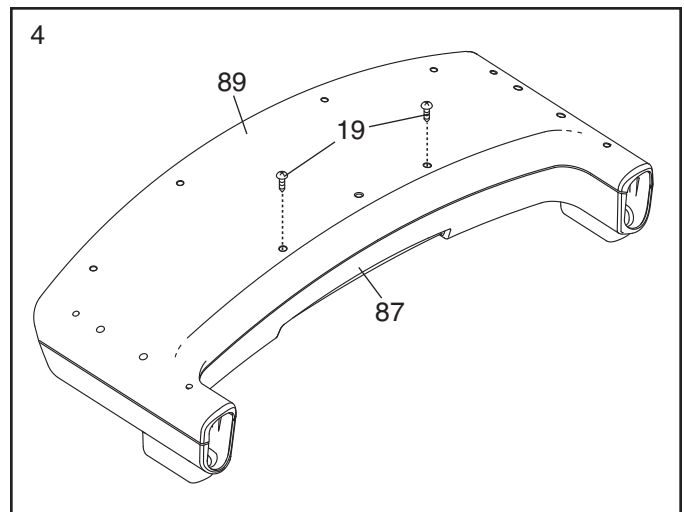

5. Position the Console Crossbar (103) between the Uprights (77, 79) as shown. Attach the Console Crossbar to the Uprights with four 5/16" x 2 3/4" Bolts (4) and four 5/16" Star Washers (9); **do not fully tighten the Bolts yet.**

Remove the wire tie from the Upright Wire (78).

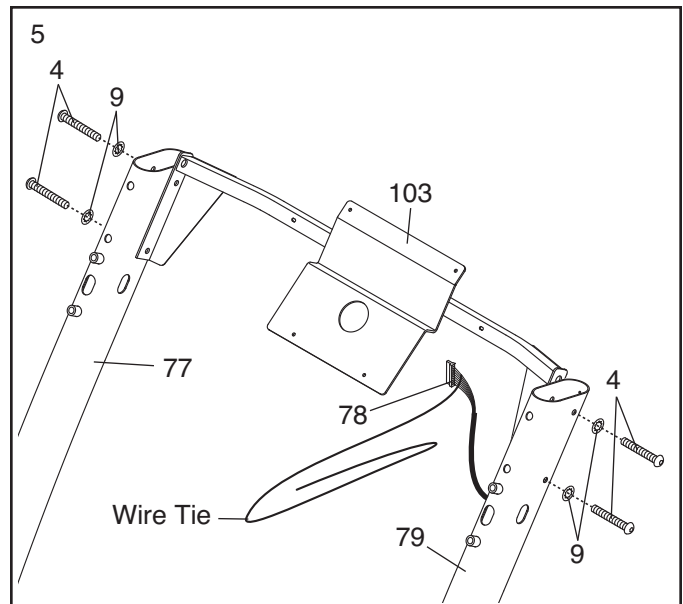

6. Set the Console Cover (87) on the Uprights (77, 79). Make sure that the Console Cover is oriented with the ties toward the bottom as shown.

Attach the Console Cover (87) with the two #8 x 1 1/2" Screws (19) that you removed in step 4. **Start both Screws, and then tighten each of them; do not overtighten the Screws.**

Insert the Upright Wire (78) through the loops in the ties.

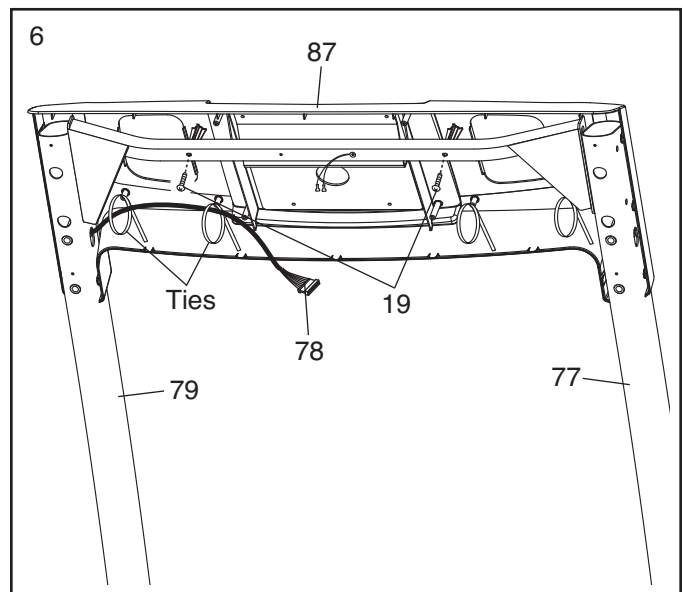

7. Have a second person hold the Left Pulse Handrail (86) near the Left Upright (77). Insert the Left Pulse Wire (90) from the Left Pulse Handrail through the hole in the Left Upright and out of the hole in the side of the Left Upright. Then, insert the Left Pulse Wire through the loops in the ties.

Attach the Left Pulse Handrail (86) to the Left Upright (77) with two 3/8" x 5" Patch Bolts (34) and two 3/8" Star Washers (8). **Start all four Patch Bolts, and then tighten each of them.**

Attach the Right Pulse Handrail (102) to the Right Upright (79) as described above.

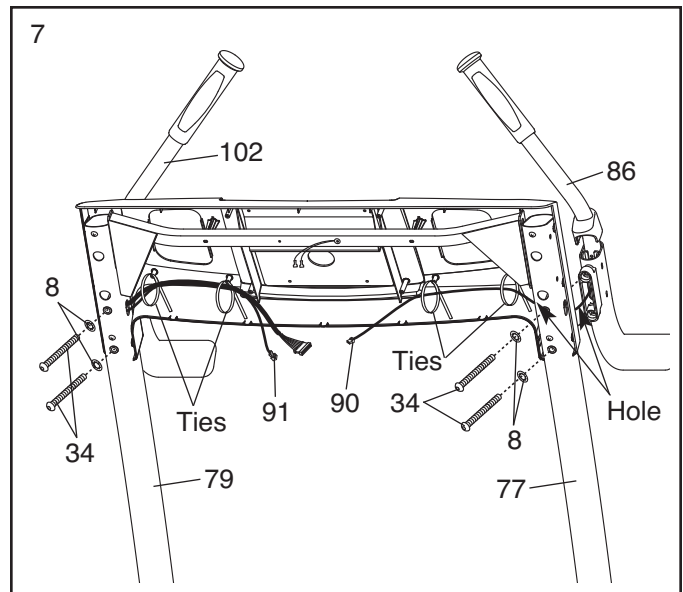

8. Have a second person hold the Console (85) near the Console Cover (87). Insert the wires from the Console through the indicated hole.

Connect the Upright Wire (78), the Left and Right Pulse Wires (90, 91), and the Ground Wires (97) to the wires extending from the Console (85). **See the inset drawing. The connectors should slide together easily and snap into place.** If they do not, turn one connector and try again. **IF YOU DO NOT CONNECT THE CONNECTORS PROPERLY, THE CONSOLE MAY BECOME DAMAGED WHEN YOU TURN ON THE POWER.**

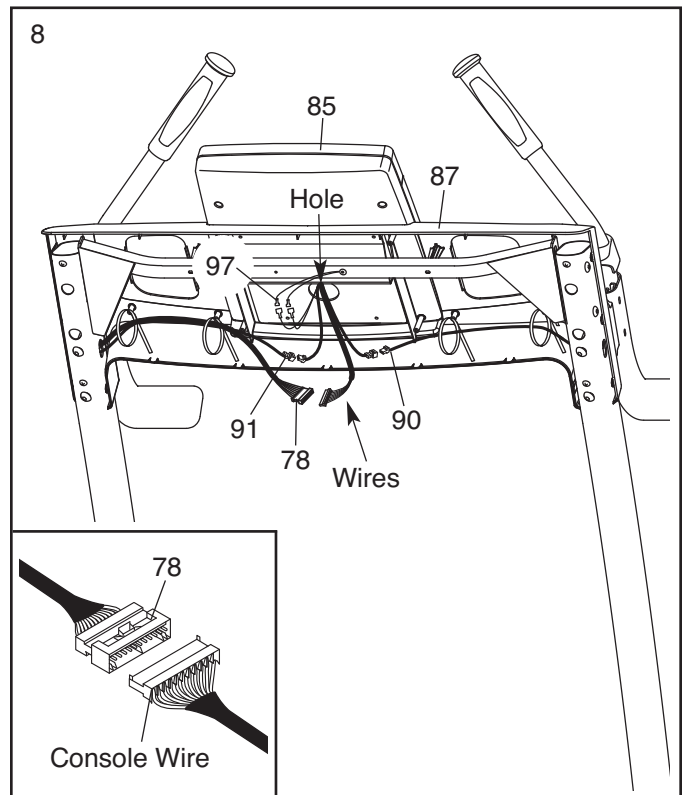

9. Attach the Console (85) with four #8 x 3/4" Screws (1). **Start all four Screws, and then tighten each of them; do not overtighten the Screws.**

Tighten the four loops around the wires by pulling on the ends of the ties.

See step 5. Tighten the 5/16" x 2 3/4" Bolts (4).

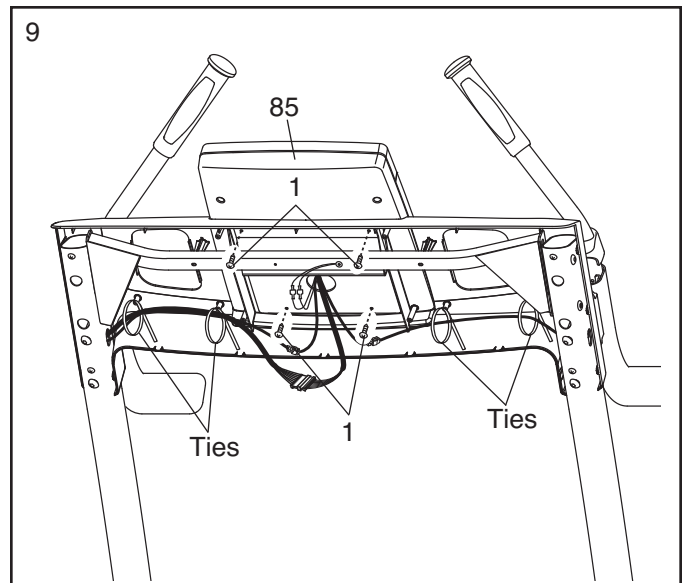

10. Attach the Console Back (89) to the Console Cover (87) with two #8 x 1 1/2" Screws (19) and twelve #8 x 3/4" Screws (1). **Start all fourteen Screws, and then tighten each of them; do not overtighten the Screws. Make sure no wires are pinched.**

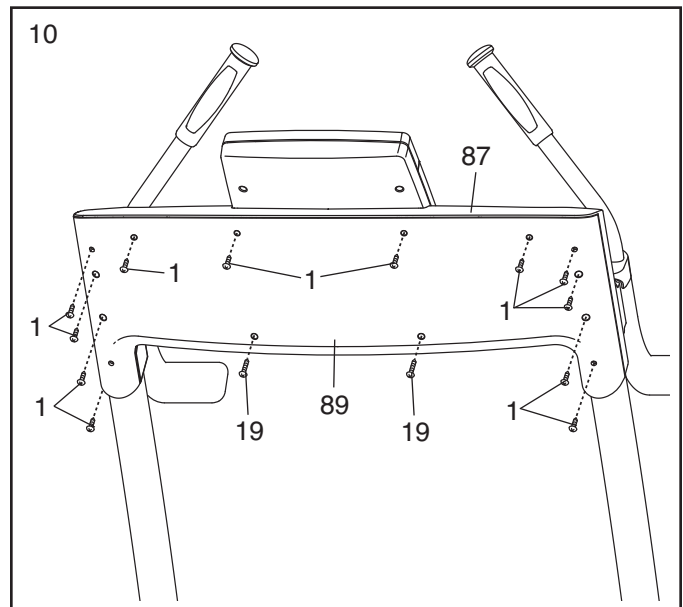

11. Press the Left and Right Accessory Trays (99, 100) into the Console Cover (87).

Slide the two Handrail Covers (76) down against the Handrails (88).

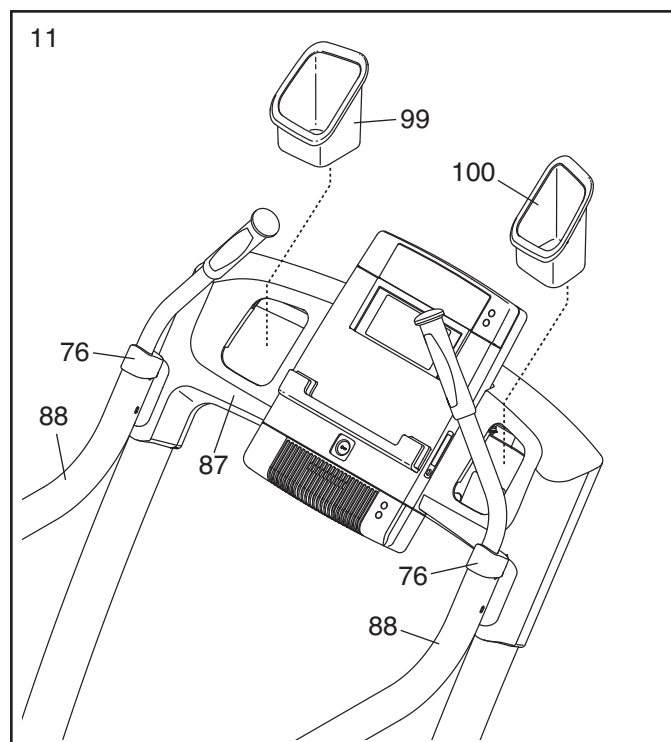

12. **Make sure that all parts are properly tightened before you use the incline trainer.** Keep the included hex keys in a secure place. One of the hex keys is used to adjust the walking belt (see pages 24 and 25). **To protect the floor or carpet from damage, place a mat under the incline trainer.**

OPERATION AND ADJUSTMENT

THE PRE-LUBRICATED WALKING BELT

Your incline trainer features a walking belt coated with high-performance lubricant. **IMPORTANT: Never apply silicone spray or other substances to the walking belt or the walking platform. Such substances will cause excessive wear.**

HOW TO PLUG IN THE POWER CORD

⚠ DANGER: Improper connection of the equipment-grounding conductor increases the risk of electric shock. Check with a qualified electrician or serviceman if you are unsure whether the product is properly grounded. Do not modify the plug—if it will not fit the outlet, have a proper outlet installed by a qualified electrician.

Your incline trainer, like other electronic equipment, can be damaged by sudden voltage changes in your home's power. **To decrease the risk of damaging your incline trainer, always use a surge suppressor with your incline trainer (see drawing 1 at the right). To purchase a surge suppressor, see precaution 12 on page 3.**

Use only a single-outlet surge suppressor that is UL 1449 listed as a transient voltage surge suppressor (TVSS). The surge suppressor must have a UL suppressed voltage rating of 400 volts or less and a minimum surge dissipation of 450 joules. The surge suppressor must be electrically rated for 120 volts AC and 15 amps. There must be a monitoring light on the surge suppressor to indicate whether it is functioning properly. Failure to use a properly functioning surge suppressor could damage the control system of the incline trainer (see precaution 13 on page 3).

This product must be grounded. If it should malfunction or break down, grounding provides a path of least resistance for electric current to reduce the risk of electric shock. This product's power cord has an equipment-grounding conductor and a grounding plug. **Plug the power cord into a surge suppressor, and plug the surge suppressor into an appropriate outlet**

that is properly installed and grounded in accordance with all local codes and ordinances. **IMPORTANT: The incline trainer is not compatible with GFCI-equipped outlets.**

This product is for use on a nominal 120-volt circuit (see drawing 1). A temporary adapter may be used to connect the surge suppressor to a 2-pole receptacle if a properly grounded outlet is not available (see drawing 2).

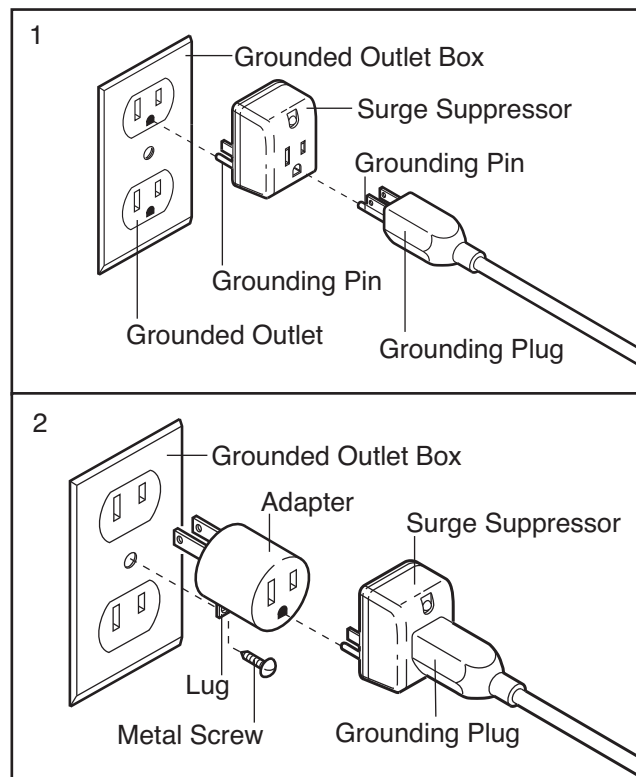

The temporary adapter should be used only until a properly grounded outlet (see drawing 1) can be installed by a qualified electrician.

The green-colored rigid ear, lug, or the like extending from the adapter must be connected to a permanent ground such as a properly grounded outlet box cover. The adapter must be held in place by a metal screw. **Some 2-pole receptacle outlet box covers are not grounded. Contact a qualified electrician to determine if the outlet box cover is grounded before using an adapter.**

CONSOLE DIAGRAM

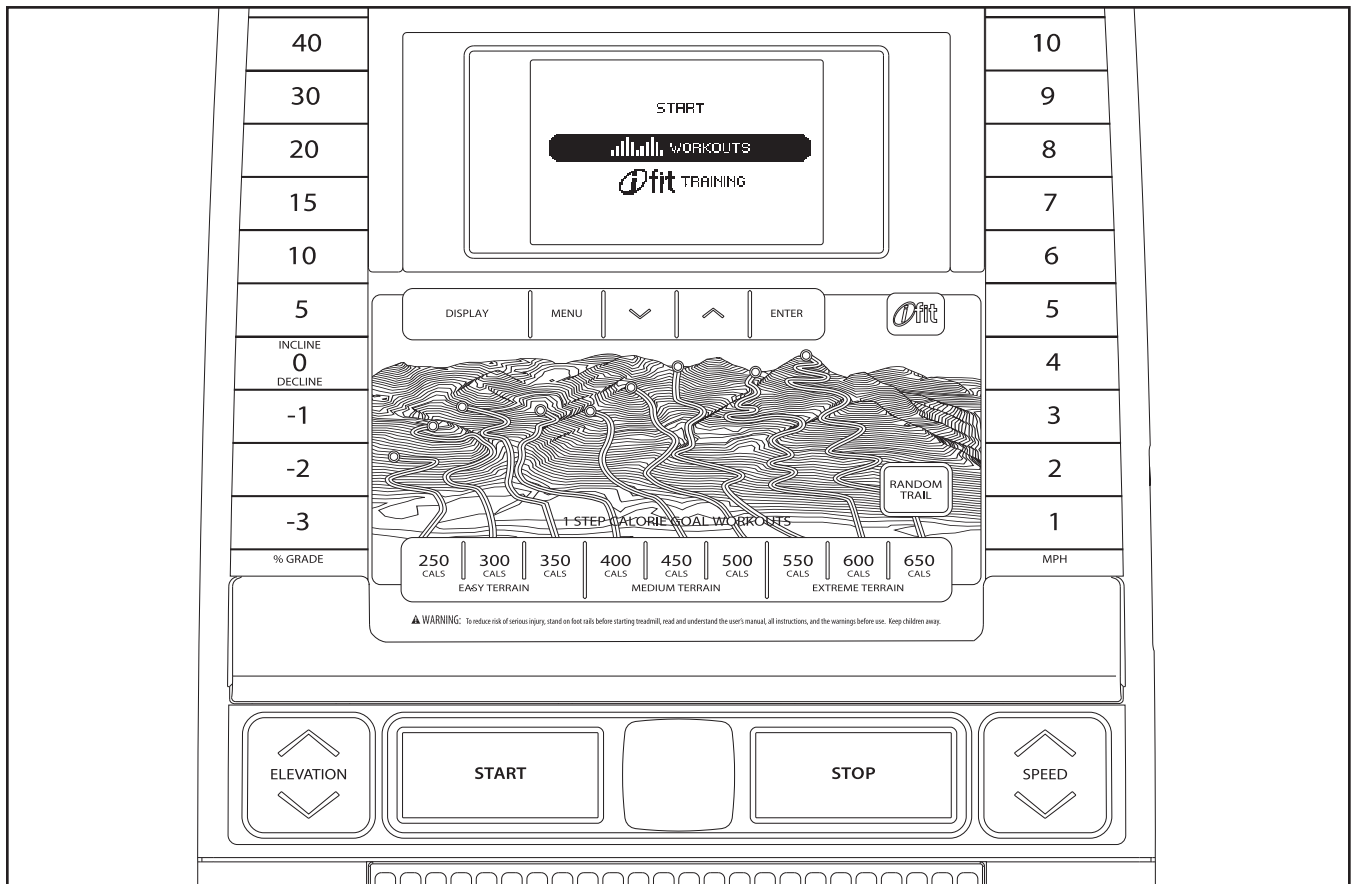

FEATURES OF THE CONSOLE

The incline trainer console offers an impressive array of features designed to make your workouts more effective and enjoyable. When the manual mode of the console is selected, the speed and incline of the incline trainer can be changed with the touch of a button. As you exercise, the console will display continuous exercise feedback. You can even measure your heart rate using the handgrip pulse sensor.

In addition, the console features nine calorie workouts. Each workout automatically controls the speed and incline of the incline trainer as it guides you through an effective exercise session. You can even use the random workout generator to get a new workout every time you exercise.

The console also features an iFit training mode that enables the incline trainer to communicate with your

wireless network through an optional iFit Live module. With the iFit training mode, you can download personalized workouts, create your own workouts, track your workout results, and access many other features. **To purchase an iFit Live module at any time, go to www.iFit.com or call the telephone number on the front cover of this manual.**

You can also listen to your favorite workout music or audio books with the console's premium stereo sound system while you get in shape.

To turn on the power, see page 16. To use the manual mode, see page 16. To use a calorie workout, see page 18. To use a random workout, see page 19. To use the information mode, see page 20. To use the stereo sound system, see page 21. To use the iFit training mode, see page 21.

HOW TO TURN ON THE POWER

IMPORTANT: If the incline trainer has been exposed to cold temperatures, allow it to warm to room temperature before turning on the power. If you do not do this, you may damage the console displays or other electrical components.

Plug in the power cord (see page 14). Next, locate the power switch on the incline trainer frame near the power cord. Make sure that the switch is in the reset position.

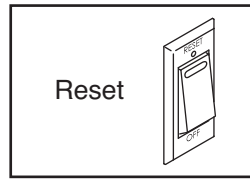

IMPORTANT: The console features a display demo mode, designed to be used if the incline trainer is displayed in a store. If the displays light as soon as you plug in the power cord and press the power switch into the reset position, the demo mode is turned on. To turn off the demo mode, hold down the Stop button for a few seconds. If the displays remain lit, see THE INFORMATION MODE on page 20 to turn off the demo mode.

Next, stand on the walking platform of the incline trainer. Locate the clip attached to the key, and slide the clip securely onto the waistband of your clothes. Then, insert the key into the console. After a moment,

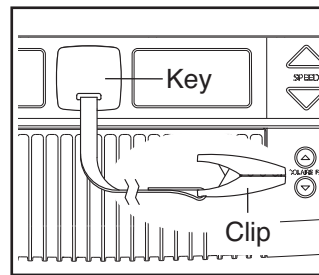

the displays will light. **IMPORTANT:** In an emergency, the key can be pulled from the console, causing the walking belt to slow to a stop. Test the clip by carefully taking a few steps backward; if the key is not pulled from the console, adjust the position of the clip.

IMPORTANT: If there is a sheet of plastic on the face of the console, remove the plastic. To prevent damage to the walking platform, wear clean athletic shoes while using the incline trainer. The first time the incline trainer is used, observe the alignment of the walking belt, and center the walking belt if necessary (see page 25).

Note: The console can display speed and distance in either miles or kilometers. To find which unit of measurement is selected, see THE INFORMATION MODE on page 20. For simplicity, all instructions in this manual refer to miles.

HOW TO USE THE MANUAL MODE

1. Insert the key into the console.

See HOW TO TURN ON THE POWER at the left. If necessary, press the Incline buttons to adjust the incline level to 0 percent.

2. Select the manual mode.

Each time the key is inserted, the main menu will appear. To select the manual mode, use the increase and decrease buttons next to the Enter button and highlight START. Press the Enter button. If you have selected a workout or the iFit training mode, press the Menu button to return to the main menu.

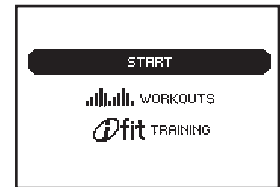

3. Start the walking belt and adjust the speed.

To start the walking belt, press the Start button, the Speed increase button, or one of the numbered speed buttons.

If you press the Start button or the Speed increase button, the walking belt will begin to move at 1 mph. As you exercise, change the speed of the walking belt as desired by pressing the Speed increase and decrease buttons. Each time you press one of the buttons, the speed setting will change by 0.1 mph; if you hold down the button, the speed setting will change in increments of 0.5 mph.

If you press one of the numbered speed buttons, the walking belt will gradually change speed until it reaches the selected speed setting. To select a speed setting that includes a decimal—such as 3.5 mph—press two numbered buttons in succession. For example, to select a speed setting of 3.5 mph, press the 3 button and then immediately press the 5 button.

To stop the walking belt, press the Stop button. To restart the walking belt, press the Start button, the Speed increase button, or one of the numbered speed buttons.

4. Change the incline of the incline trainer as desired.

To change the incline of the incline trainer, press the Incline increase and decrease buttons or one of the incline buttons numbered -3 to 40. Each time you press one of the buttons, the incline will gradually change until it reaches the selected incline setting.

Note: As the incline changes, the maximum speed of the incline trainer will change. When the incline is from -3% to -2.5%, the maximum speed will be 8 mph; when the incline is from -2% to -1.5%, the maximum speed will be 8.5 mph; when the incline is from -1% to -0.5%, the maximum speed will be 9 mph; when the incline is from 0% to 15%, the maximum speed will be 10 mph; when the incline is from 15.5% to 25%, the maximum speed will be 8 mph; and when the incline is from 25.5% to 40%, the maximum speed will be 6 mph.

5. Monitor your progress with the display.

The console offers several display modes. The display mode that you select will determine which workout information is shown. To select the desired display mode, repeatedly press the Display button or the increase and decrease buttons next to the Enter button.

As you walk or run on the incline trainer, the center display can show the following workout information:

- The incline level of the incline trainer
- The speed of the walking belt
- The elapsed time
- The distance that you have walked or run
- The approximate number of calories you have burned
- Your pace in minutes per mile or minutes per kilometer
- Your heart rate (see step 6 on this page)

Regardless of which display mode you select, the speed and incline settings will appear in the display for a few seconds each time you change the setting.

If desired, adjust the volume level by pressing the Volume (VOL) increase and decrease buttons on the console.

To reset the console, press the Stop button, remove the key, and then reinsert the key.

6. Measure your heart rate if desired.

Before using the handgrip pulse sensor, remove the sheets of plastic from the metal contacts if necessary. In addition, make sure that your hands are clean.

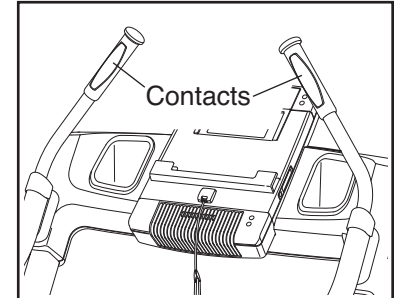

To measure your heart rate, **stand on the walking platform** and hold the metal contacts on the handrail for approximately ten seconds—**avoid moving your hands**. When your pulse is detected, your heart rate will be shown. **For the most accurate heart rate reading, continue to hold the contacts for about 15 seconds.**

7. Turn on the fan if desired.

The fan features low and high speed settings. Press the Coolaire Fan increase and decrease buttons repeatedly to select a fan speed or to turn off the fan. Note: If the fan is on when the walking belt is stopped, the fan will turn off automatically after a few minutes.

8. When you are finished exercising, remove the key from the console.

Step onto the walking platform and press the Stop button. Next, remove the key from the console and put it in a secure place.

When you are finished using the incline trainer, press the power switch into the off position and unplug the power cord. **IMPORTANT: If you do not do this, the incline trainer's electrical components may wear prematurely.**

HOW TO USE A CALORIE WORKOUT

1. Insert the key into the console.

See step 1 on page 16.

2. Select a calorie workout.

If you have selected the manual mode, a workout, or the iFit training mode, press the Menu button to return to the main menu.

To select a calorie workout, use the increase and decrease buttons next to the Enter button and highlight WORKOUTS. Press the Enter button. Then, press the increase and decrease buttons to highlight the desired workout category and press the Enter button. You can also press the Cals buttons on the console.

Use the increase and decrease buttons to select the desired workout. When you select a workout, the display will show the name of the workout, the maximum speed setting, the maximum incline setting, and a profile of the speed settings of the workout.

3. Start the workout.

Press the Start button to start the workout. A moment after you press the button, the walking belt will begin to move. Hold the handrails and begin walking.

Each calorie workout is divided into segments. One speed setting and one incline setting are programmed for each segment. Note: The same speed setting and/or incline setting may be programmed for consecutive segments.

During the workout, the profile will show your progress. Press the Display button repeatedly to view the profile. The

flashing segment of the profile represents the current segment of the workout. The height of the flashing segment indicates the speed setting for the current segment.

At the end of the first segment of the workout, a series of tones will sound. If a different speed and/or incline setting is programmed for the second seg-

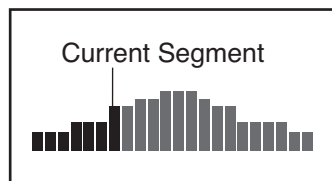

ment, the speed setting and/or incline setting will appear in the display for a moment to alert you and the incline trainer will automatically adjust to the speed and incline settings for the next segment.

The workout will continue in this way until the last segment of the profile flashes in the display and the last segment ends. The walking belt will then slow to a stop.

If the speed or incline setting is too high or too low at any time during the workout, you can override the setting by pressing the Speed or Incline buttons; **however, when the next segment begins, the incline trainer will automatically adjust to the speed and incline settings for the next segment.**

To stop the workout at any time, press the Stop button. To restart the workout, press the Start button. The walking belt will begin to move at 1 mph. When the next segment of the workout begins, the incline trainer will automatically adjust to the speed and incline settings for the next segment.

Note: The calorie goal is an estimate of the number of calories that you will burn during the workout. The actual number of calories that you burn will depend on your weight. In addition, if you manually change the speed or incline of the incline trainer during the workout, the number of calories you burn will be affected.

4. Monitor your progress with the display.

See step 5 on page 17. When a calorie workout is selected, the console can also show a flame representing 25 calories and a profile of the speed settings of the workout.

5. Measure your heart rate if desired.

See step 6 on page 17.

6. Turn on the fan if desired.

See step 7 on page 17.

7. When you are finished exercising, remove the key from the console.

See step 8 on page 17.

HOW TO USE A RANDOM WORKOUT

1. Insert the key into the console.

See step 1 on page 16.

2. Select a random workout.

If you have selected the manual mode, a workout, or the iFit training mode, press the Menu button to return to the main menu.

To select a random workout, use the increase and decrease buttons next to the Enter button and highlight WORKOUTS. Press the Enter button. Then, press the increase and decrease buttons to highlight RANDOM TRAIL and press the Enter button.

Press one of the Cals buttons to select the desired number of calories. The incline trainer will create a new workout based on random speed and incline settings. Press the Cals button repeatedly to create different workouts.

When you select a workout, the display will show the name of the workout, the maximum speed setting, the maximum incline setting, and a profile of the speed settings of the workout.

3. Start the workout.

Press the Start button to start the workout. A moment after you press the button, the walking belt will begin to move. Hold the handrails and begin walking.

Each random workout is divided into segments. One speed setting and one incline setting are programmed for each segment. Note: The same speed setting and/or incline setting may be programmed for consecutive segments.

During the workout, the profile will show your progress. Press the Display button repeatedly to view the profile. The

flashing segment of the profile represents the current segment of the workout. The height of the flashing segment indicates the speed setting for the current segment.

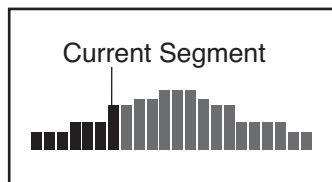

At the end of the first segment of the workout, a series of tones will sound. If a different speed and/or incline setting is programmed for the second segment, the speed setting and/or incline setting will appear in the display for a moment to alert you and the incline trainer will automatically adjust to the speed and incline settings for the next segment.

The workout will continue in this way until the last segment of the profile flashes in the display and the last segment ends. The walking belt will then slow to a stop.

If the speed or incline setting is too high or too low at any time during the workout, you can override the setting by pressing the Speed or Incline buttons; **however, when the next segment begins, the incline trainer will automatically adjust to the speed and incline settings for the next segment.**

To stop the workout at any time, press the Stop button. To restart the workout, press the Start button. The walking belt will begin to move at 1 mph. When the next segment of the workout begins, the incline trainer will automatically adjust to the speed and incline settings for the next segment.

Note: The calorie goal is an estimate of the number of calories that you will burn during the workout. The actual number of calories that you burn will depend on your weight. In addition, if you manually change the speed or incline of the incline trainer during the workout, the number of calories you burn will be affected.

4. Monitor your progress with the display.

See step 4 on page 18.

5. Measure your heart rate if desired.

See step 6 on page 17.

6. Turn on the fan if desired.

See step 7 on page 17.

7. When you are finished exercising, remove the key from the console.

See step 8 on page 17.

THE INFORMATION MODE

The console features an information mode that keeps track of the total distance that the walking belt has moved and the total number of hours that the incline trainer has been used. The information mode also allows you to select miles or kilometers to measure distance, and to turn on and turn off the display demo mode. You can also adjust the contrast level of the display and view the status of the optional iFit Live module.

To select the information mode, hold down the Stop button, insert the key into the console, and then release the Stop button. When the information mode is selected, the following information will appear in the display:

The display will show the total number of miles that the walking belt has moved and the total number of hours the incline trainer has been used.

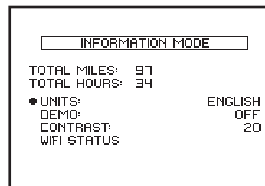

The display will show the selected unit of measurement. To change the unit of measurement, press the Speed increase button. To view distance in miles, select ENGLISH. To view distance in kilometers, select METRIC.

The console features a display demo mode, designed to be used if the incline trainer is displayed in a store. While the demo mode is turned on, the console will function normally when you plug in the power cord, press the power switch into the reset position, and insert the key into the console. However, when you remove the key, the displays will remain lit, although the buttons will not function. If the demo mode is turned on, the word "ON" will appear in display while the information mode is selected. To turn on or turn off the demo mode, press the Speed decrease button.

The display will also show the contrast level of the display. Press the Incline increase and decrease buttons to adjust the contrast.

The display will show whether an accessory is plugged into the console. If the iFit Live module is plugged in, the display will show the words "WIFI STATUS." If a USB device is plugged in, the display will show the words "USB STATUS." If nothing is plugged in, the display will show the words "NO MODULE DETECTED."

To exit the information mode, remove the key from the console.

HOW TO USE THE STEREO SOUND SYSTEM

To play music or audio books through the console's speakers, you must connect your MP3 player, CD player, or other personal audio player to the console.

Locate the audio wire. Plug one end into the audio jack on the side of the console. Then, plug the audio wire into a jack on your MP3 player, CD player, or personal audio player. **Make sure that the audio wire is fully plugged in.**

Next, press the Play button on your MP3 player, CD player, or other personal audio player. Then, adjust the volume level on your personal audio player or press the Volume increase and decrease buttons on the console.

If you are using a personal CD player and the CD skips, set the CD player on the floor or another flat surface instead of on the console.

HOW TO USE THE IFIT TRAINING MODE

The optional iFit Live module allows your incline trainer to communicate with your wireless network and unlocks exciting new features. For example, you can download personalized workouts, create your own workouts, track your workout results, and access many other features. **To purchase an iFit Live module at any time, go to www.iFit.com or call the telephone number on the front cover of this manual.** You must have an iFit Live module to use the iFit training mode.

To use the iFit training mode, insert the iFit Live module into the console. Use the increase and decrease buttons next to the Enter button and highlight IFIT TRAINING. Press the Enter button.

For more information on the iFit training mode, go to www.iFit.com. Note: To use an iFit Live module, you must have access to a computer with an internet connection and a USB port. You must also have your own wireless network including an 802.11b router with SSID broadcast enabled (hidden networks are not supported). You will also need an iFit.com membership.

HOW TO MOVE THE INCLINE TRAINER

Before moving the incline trainer, insert the key into the console, raise the incline to the maximum incline level, remove the key, and unplug the power cord.

Due to the size and weight of the incline trainer, moving it requires two or three persons. Hold the upright firmly near the console. Tip the incline trainer back until it rolls freely on the wheels. **CAUTION: To decrease the possibility of injury or of damage to the incline trainer, do not lift the incline trainer by the plastic belly pan. Do not pull on the console.** Carefully roll the incline trainer on the wheels to the desired location and then lower it to the level position. **CAUTION: To reduce the risk of injury, use extreme caution while moving the incline trainer. Do not attempt to move the incline trainer over uneven surfaces.**

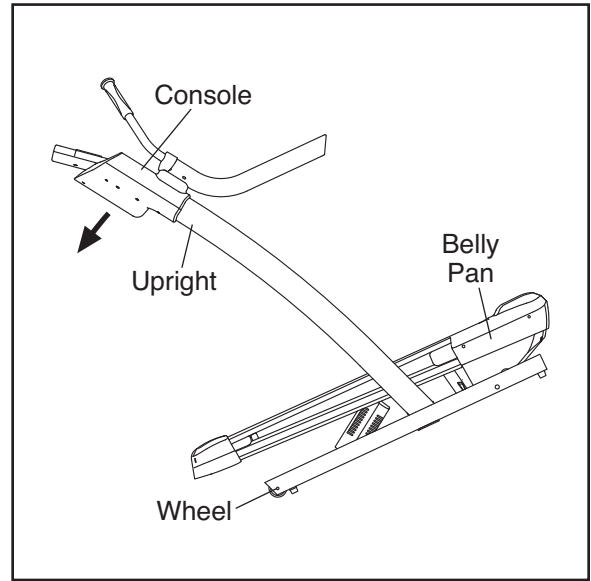

TROUBLESHOOTING

Most incline trainer problems can be solved by following the steps below. Find the symptom that applies, and follow the steps listed. If further assistance is needed, please see the front cover of this manual.

PROBLEM: The power does not turn on

SOLUTION: a. Make sure that the power cord is plugged into a surge suppressor, and that the surge suppressor is plugged into a properly grounded outlet (see page 14). Use only a single-outlet surge suppressor that meets all of the specifications described on page 14. **IMPORTANT: The incline trainer is not compatible with GFCI-equipped outlets.**

b. After the power cord has been plugged in, make sure that the key is inserted into the console.

c. Check the power switch located on the incline trainer frame near the power cord. If the switch protrudes as shown, the switch has tripped. To reset the switch, wait for five minutes and then press the switch back in.

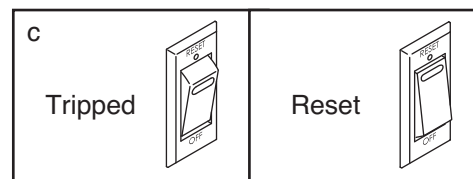

PROBLEM: The power turns off during use

SOLUTION: a. Check the power switch (see the drawing above). If the switch has tripped, wait for five minutes and then press the switch back in.

b. Make sure that the power cord is plugged in. If the power cord is plugged in, unplug it, wait for five minutes, and then plug it back in.

c. Remove the key from the console. Reinsert the key into the console.

d. If the incline trainer still will not run, please see the front cover of this manual.

PROBLEM: The console displays remain lit when you remove the key from the console

SOLUTION: a. The console features a display demo mode, designed to be used if the incline trainer is displayed in a store. If the displays remain lit when you remove the key, the demo mode is turned on. To turn off the demo mode, hold down the Stop button for a few seconds. If the displays are still lit, see THE INFORMATION MODE on page 20 to turn off the demo mode.

PROBLEM: The displays of the console do not function properly

SOLUTION: a. Remove the key from the console and **UNPLUG THE POWER CORD**. Next, remove the three indicated #8 x 1/2" Cover Screws (18). Then, lift off the Left Roller Cover (38).

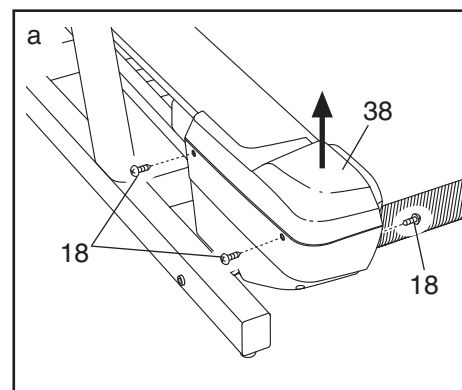

Locate the Reed Switch (55) and the Magnet (41) on the left side of the Pulley (42). Turn the Pulley until the Magnet is aligned with the Reed Switch. **Make sure that the gap between the Magnet and the Reed Switch is about 1/8 in. (3 mm).** If necessary, loosen the #8 x 3/4" Clamp Screw (20), move the Reed Switch slightly, and then retighten the Screw. Reattach the Left Roller Cover (not shown) and run the incline trainer for a few minutes to check for a correct speed reading.

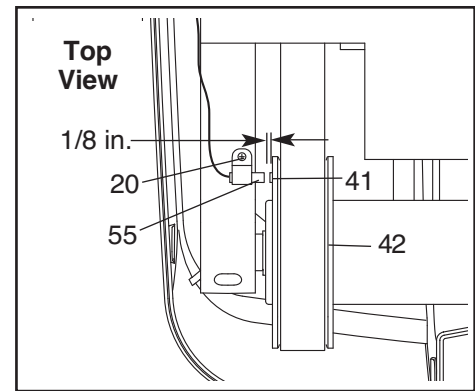

PROBLEM: The incline of the incline trainer does not change correctly

SOLUTION: a. Hold down the Stop button and the Speed increase button, insert the key into the console, and then release the Stop button and the Speed increase button. Press the Stop button again. Then, press the Incline increase or decrease button. The incline trainer will automatically rise to the maximum incline level and then return to the minimum level. This will recalibrate the incline system. If the incline does not calibrate, press the Stop button, and then press the Incline increase or decrease button again. When the incline is calibrated, remove the key from the console.

PROBLEM: The walking belt slows when walked on

SOLUTION: a. Use only a single-outlet surge suppressor that meets all of the specifications described on page 14.

b. If the walking belt is overtightened, incline trainer performance may decrease and the walking belt may become damaged. Remove the key and **UNPLUG THE POWER CORD.** Using the hex key, turn both idler roller bolts counterclockwise, 1/4 of a turn. When the walking belt is properly tightened, you should be able to lift each edge of the walking belt 3 to 4 in. (8 to 10 cm) off the walking platform. Be careful to keep the walking belt centered. Then, plug in the power cord, insert the key, and run the incline trainer for a few minutes. Repeat until the walking belt is properly tightened.

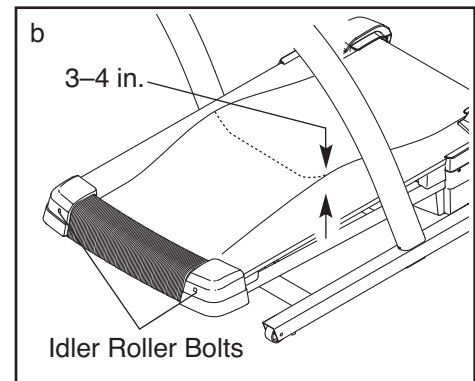

c. If the walking belt still slows when walked on, please see the front cover of this manual.

PROBLEM: The walking belt is off-center or slips when walked on

SOLUTION: a. If the walking belt is off-center, remove the key and **UNPLUG THE POWER CORD**. If the walking belt has shifted to the left, use the hex key to turn the left idler roller bolt clockwise 1/2 of a turn; if the walking belt has shifted to the right, turn the bolt counterclockwise 1/2 of a turn. Be careful not to over-tighten the walking belt. Plug in the power cord, insert the key, and run the incline trainer for a few minutes. Repeat until the walking belt is centered.

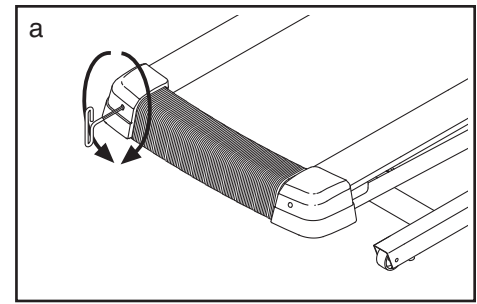

b. If the walking belt slips when walked on, first remove the key and **UNPLUG THE POWER CORD**. Using the hex key, turn both idler roller bolts clockwise, 1/4 of a turn. When the walking belt is correctly tightened, you should be able to lift each edge of the walking belt 3 to 4 in. (8 to 10 cm) off the walking platform. Be careful to keep the walking belt centered. Then, plug in the power cord, insert the key, and carefully walk on the incline trainer for a few minutes. Repeat until the walking belt is properly tightened.

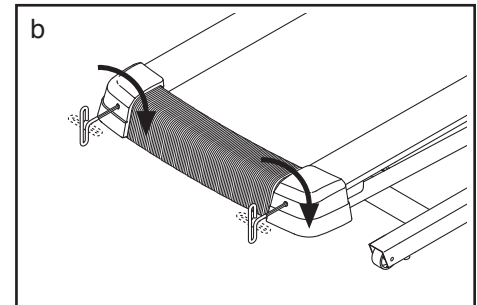

PROBLEM: The console display has lines running through it

SOLUTION: a. If lines appear in the console display, see THE INFORMATION MODE on page 20 and adjust the contrast level of the display.

EXERCISE GUIDELINES

⚠ WARNING: Before beginning any exercise program, consult your physician. This is especially important for persons over age 35 or persons with pre-existing health problems.

The pulse sensor is not a medical device. Various factors may affect the accuracy of heart rate readings. The pulse sensor is intended only as an exercise aid in determining heart rate trends in general.

These guidelines will help you to plan your exercise program. For detailed exercise information, obtain a reputable book or consult your physician. Remember, proper nutrition and adequate rest are essential for successful results.

EXERCISE INTENSITY

Whether your goal is to burn fat or to strengthen your cardiovascular system, exercising at the proper intensity is the key to achieving results. You can use your heart rate as a guide to find the proper intensity level. The chart below shows recommended heart rates for fat burning and aerobic exercise.

| | | | | | | | |
|-------|-----|-----|-----|-----|-----|-----|---|
| 165 | 155 | 145 | 140 | 130 | 125 | 115 | ♥ |
| 145 | 138 | 130 | 125 | 118 | 110 | 103 | ♥ |
| 125 | 120 | 115 | 110 | 105 | 95 | 90 | ♥ |
| <hr/> | | | | | | | |
| 20 | 30 | 40 | 50 | 60 | 70 | 80 | |

To find the proper intensity level, find your age at the bottom of the chart (ages are rounded off to the nearest ten years). The three numbers listed above your age define your “training zone.” The lowest number is the heart rate for fat burning, the middle number is the heart rate for maximum fat burning, and the highest number is the heart rate for aerobic exercise.

Burning Fat—To burn fat effectively, you must exercise at a low intensity level for a sustained period of time. During the first few minutes of exercise, your body uses *carbohydrate calories* for energy. Only after the first few minutes of exercise does your body begin to use stored *fat calories* for energy. If your goal is to burn fat, adjust the intensity of your exercise until your heart rate is near the lowest number in your training zone. For maximum fat burning, exercise with your heart rate near the middle number in your training zone.

Aerobic Exercise—If your goal is to strengthen your cardiovascular system, you must perform aerobic exercise, which is activity that requires large amounts of oxygen for prolonged periods of time. For aerobic exercise, adjust the intensity of your exercise until your heart rate is near the highest number in your training zone.

WORKOUT GUIDELINES

Warming Up—Start with 5 to 10 minutes of stretching and light exercise. A warm-up increases your body temperature, heart rate, and circulation in preparation for exercise.

Training Zone Exercise—Exercise for 20 to 30 minutes with your heart rate in your training zone. (During the first few weeks of your exercise program, do not keep your heart rate in your training zone for longer than 20 minutes.) Breathe regularly and deeply as you exercise—never hold your breath.

Cooling Down—Finish with 5 to 10 minutes of stretching. Stretching increases the flexibility of your muscles and helps to prevent post-exercise problems.

EXERCISE FREQUENCY

To maintain or improve your condition, complete three workouts each week, with at least one day of rest between workouts. After a few months of regular exercise, you may complete up to five workouts each week, if desired. Remember, the key to success is to make exercise a regular and enjoyable part of your everyday life.

PART LIST—Model No. NTL15909.3

R0910A

To locate the parts listed below, see the EXPLODED DRAWING near the end of this manual.

| Key No. | Qty. | Description | Key No. | Qty. | Description |
|---------|------|--------------------------|---------|------|----------------------------|
| 1 | 48 | #8 x 3/4" Screw | 51 | 1 | Grommet |
| 2 | 4 | #8 x 1" Tek Screw | 52 | 1 | Belly Pan Cover |
| 3 | 4 | 5/16" x 1 3/8" Bolt | 53 | 1 | Power Switch |
| 4 | 4 | 5/16" x 2 3/4" Bolt | 54 | 1 | Belly Pan |
| 5 | 4 | 3/8" x 3 1/2" Patch Bolt | 55 | 1 | Reed Switch |
| 6 | 2 | 3/8" x 2 1/2" Bolt | 56 | 1 | Reed Switch Clamp |
| 7 | 2 | 3/8" Nut | 57 | 1 | Left Rear Cushion |
| 8 | 10 | 3/8" Star Washer | 58 | 1 | Frame |
| 9 | 8 | 5/16" Star Washer | 59 | 1 | Belly Pan Plate |
| 10 | 4 | Base Foot | 60 | 1 | Front Left Cushion |
| 11 | 4 | Base Foot Spacer | 61 | 1 | Front Belly Pan |
| 12 | 2 | Wheel | 62 | 1 | Right Front Cushion |
| 13 | 8 | #8 x 1/2" Screw | 63 | 1 | Top Incline Motor Cover |
| 14 | 1 | Hex Wrench | 64 | 1 | Incline Motor |
| 15 | 1 | 5/32" Hex Key | 65 | 1 | Bottom Incline Motor Cover |
| 16 | 4 | #6 x 1" Screw | 66 | 1 | Incline Motor Wire |
| 17 | 8 | #8 x 3/4" Tek Screw | 67 | 5 | Wire Clamp |
| 18 | 9 | #8 x 1/2" Cover Screw | 68 | 1 | Right Rear Cushion |
| 19 | 4 | #8 x 1 1/2" Screw | 69 | 1 | Resistor |
| 20 | 1 | #8 x 3/4" Clamp Screw | 70 | 1 | Electronics Plate |
| 21 | 4 | #8 Belt Guide Screw | 71 | 1 | Controller |
| 22 | 2 | 1/4" x 1 1/2" Bolt | 72 | 8 | 8" Wire Tie |
| 23 | 2 | 5/16" x 1 3/4" Bolt | 73 | 2 | Releasable Tie |
| 24 | 2 | 5/16" x 1 3/4" Bolt | 74 | 2 | 8" Cable Tie |
| 25 | 2 | 1/4" x 2 1/2" Bolt | 75 | 1 | Drive Motor |
| 26 | 1 | 3/8" x 1 1/2" Bolt | 76 | 2 | Handrail Cover |
| 27 | 1 | 3/8" x 2 1/4" Bolt | 77 | 1 | Left Upright |
| 28 | 2 | 3/8" x 4 1/2" Bolt | 78 | 1 | Upright Wire |
| 29 | 2 | 1/4" Motor Bolt | 79 | 1 | Right Upright |
| 30 | 2 | #8 Star Washer | 80 | 1 | Base |
| 31 | 4 | 1/4" Star Washer | 81 | 2 | Round Grommet |
| 32 | 4 | 3/8" Jam Nut | 82 | 2 | Caution Decal |
| 33 | 4 | 5/16" Nut | 83 | 1 | Warning Decal |
| 34 | 4 | 3/8" x 5" Patch Bolt | 84 | 2 | Base Cap |
| 35 | 15 | Clip | 85 | 1 | Console |
| 36 | 2 | Plastic Fastener | 86 | 1 | Left Pulse Handrail |
| 37 | 1 | Incline Stop Bracket | 87 | 1 | Console Cover |
| 38 | 1 | Left Roller Cover | 88 | 2 | Handrail |
| 39 | 1 | Right Roller Cover | 89 | 1 | Console Back |
| 40 | 1 | Motor Belt | 90 | 1 | Left Pulse Wire |
| 41 | 1 | Magnet | 91 | 1 | Right Pulse Wire |
| 42 | 1 | Drive Roller/Pulley | 92 | 4 | Pulse Plate |
| 43 | 2 | Belt Guide | 93 | 4 | Pulse Plate Housing |
| 44 | 1 | Walking Platform | 94 | 2 | Pulse Handle |
| 45 | 1 | Left Platform Decal | 95 | 1 | Audio Wire |
| 46 | 1 | Right Platform Decal | 96 | 1 | Console Fan |
| 47 | 1 | Idler Roller | 97 | 2 | Ground Wire |
| 48 | 1 | Walking Belt | 98 | 2 | Handrail Cap |
| 49 | 1 | Front Hood | 99 | 1 | Left Accessory Tray |
| 50 | 1 | Power Cord | 100 | 1 | Right Accessory Tray |

| Key No. | Qty. | Description | Key No. | Qty. | Description |
|---------|------|----------------------|---------|------|-------------------|
| 101 | 1 | Incline Sensor Wire | 105 | 1 | Key/Clip |
| 102 | 1 | Right Pulse Handrail | 106 | 2 | Rubber Spacer |
| 103 | 1 | Console Crossbar | 107 | 2 | 5/16" Flat Washer |
| 104 | 8 | Frame Bushing | * | – | User's Manual |

Note: Specifications are subject to change without notice. For information about ordering replacement parts, see the back cover of this manual. *These parts are not illustrated.

EXPLODED DRAWING A—Model No. NTL15909.3

R0910A

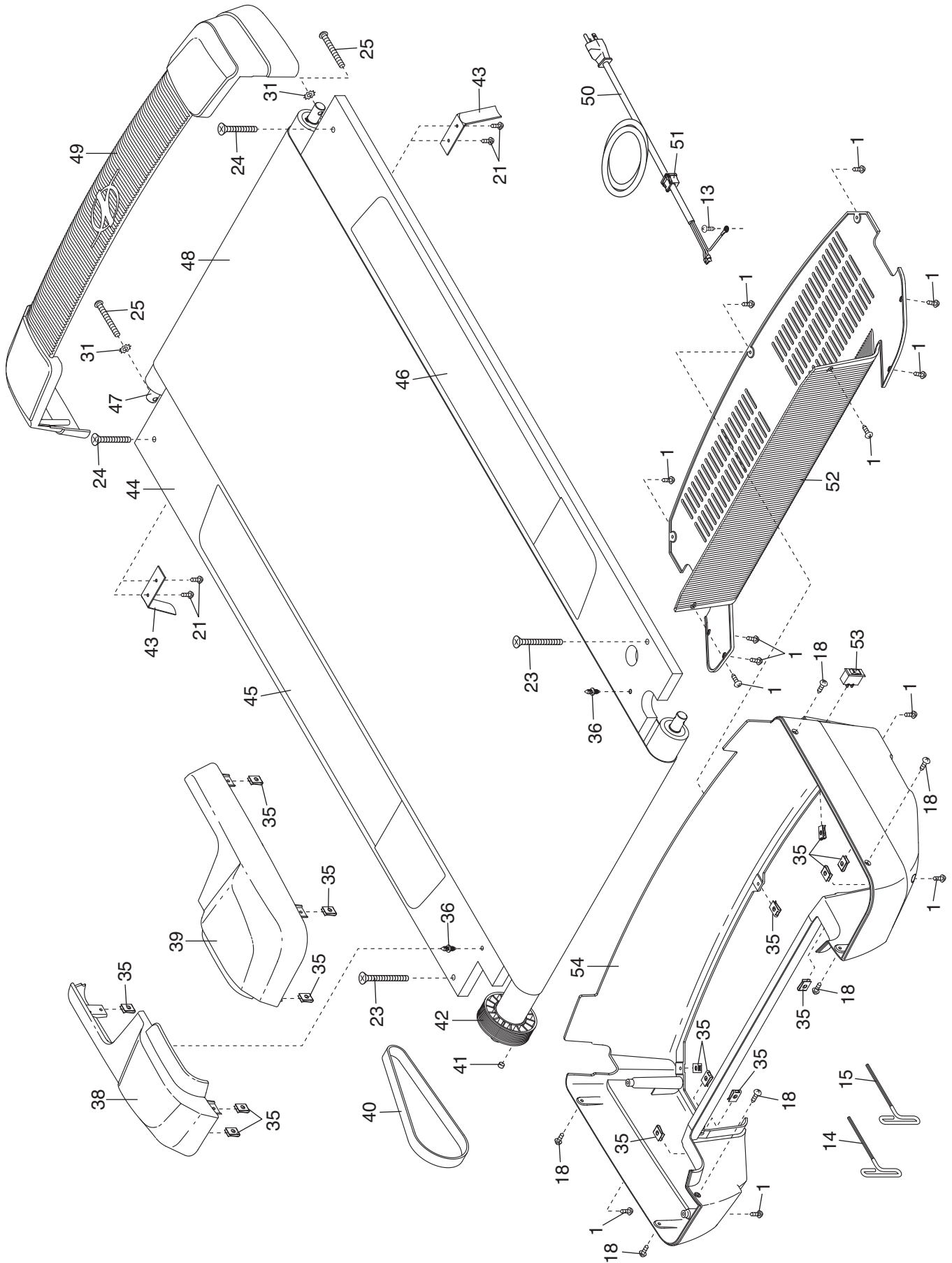

EXPLODED DRAWING B—Model No. NTL15909.3

R0910A

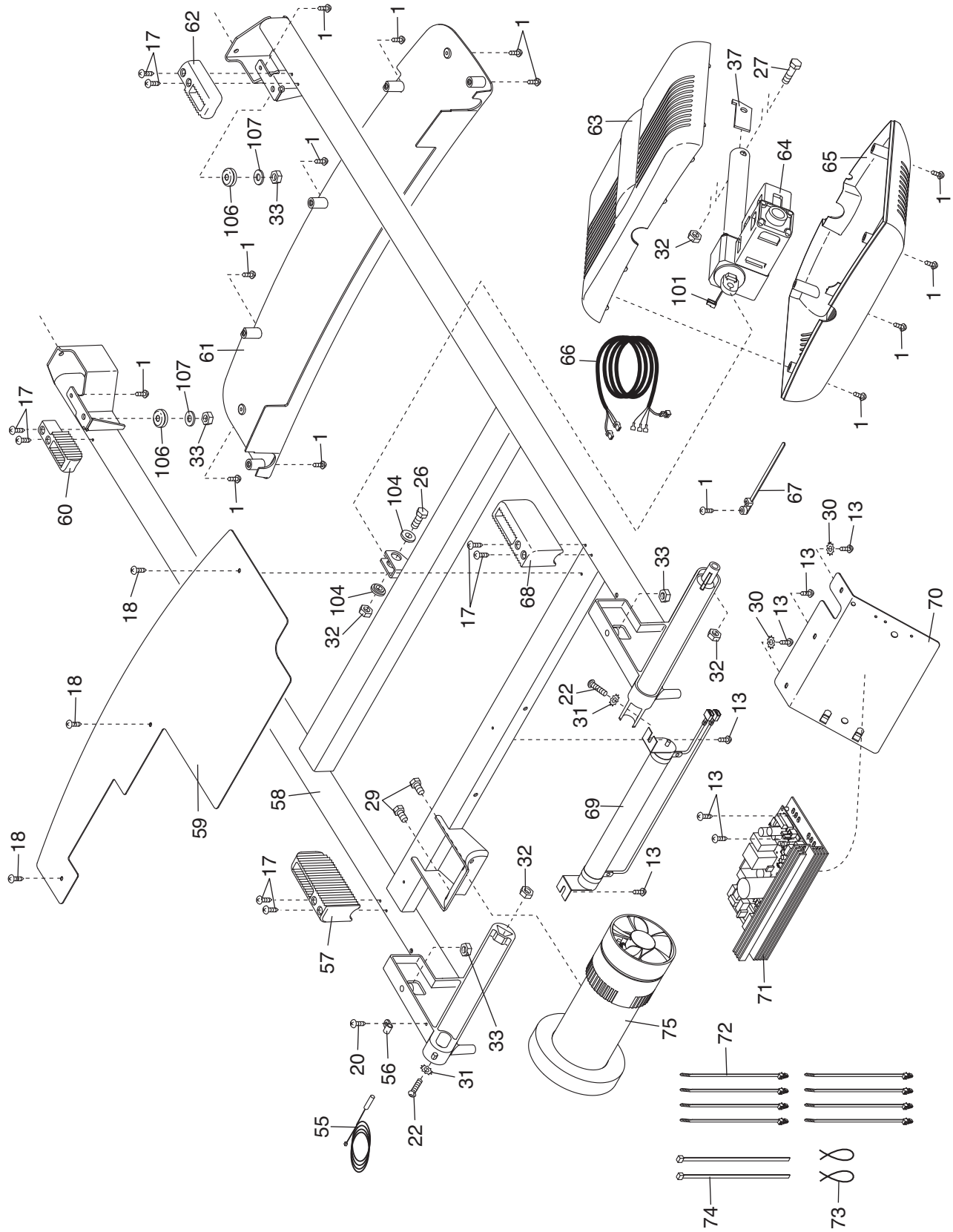

EXPLODED DRAWING C—Model No. NTL15909.3

R0910A

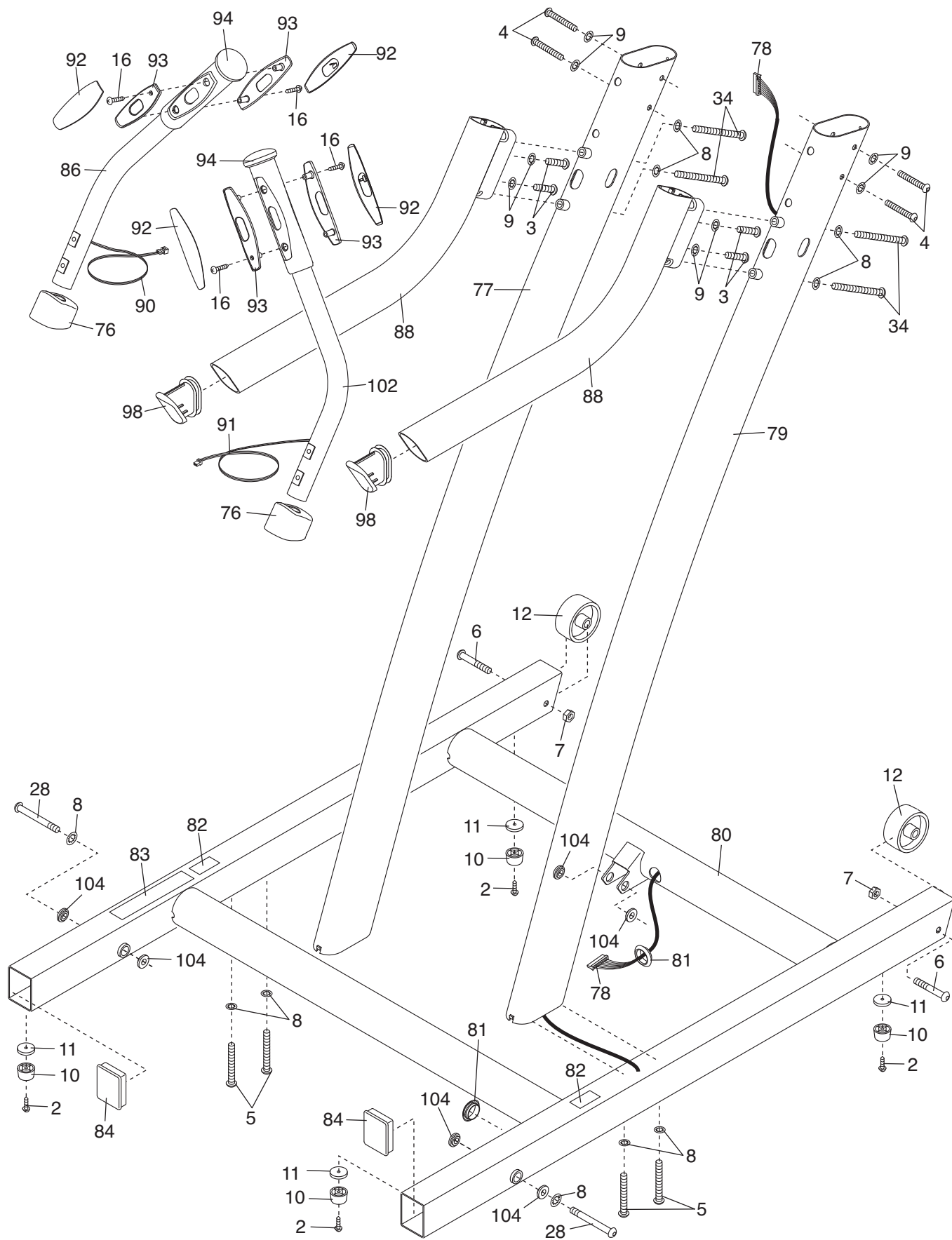

EXPLODED DRAWING D—Model No. NTL15909.3

R0910A

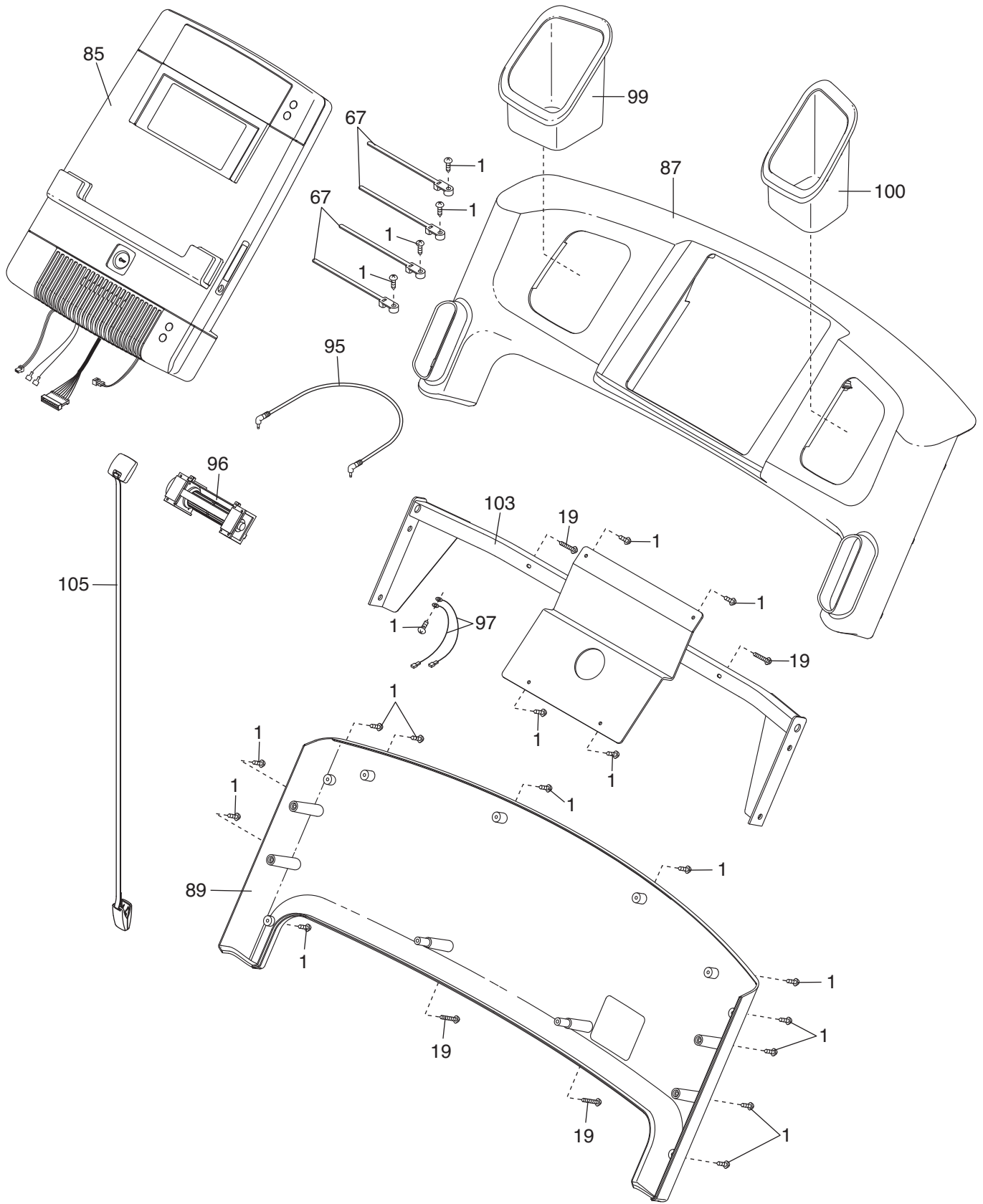

ORDERING REPLACEMENT PARTS

To order replacement parts, please see the front cover of this manual. To help us assist you, be prepared to provide the following information when contacting us:

- the model number and serial number of the product (see the front cover of this manual)
- the name of the product (see the front cover of this manual)
- the key number and description of the replacement part(s) (see the PART LIST and the EXPLODED DRAWING near the end of this manual)

LIMITED WARRANTY

IMPORTANT: You must register this product within 30 days of the purchase date to avoid added fees for service needed under warranty. Go to www.nordictrackservice.com/registration.

ICON Health & Fitness, Inc. (ICON) warrants this product to be free from defects in workmanship and material, under normal use and service conditions. The frame and drive motor are warranted for a lifetime. Parts and labor are warranted for one (1) year from the date of purchase.

This warranty extends only to the original purchaser. ICON's obligation under this warranty is limited to repairing or replacing, at ICON's option, the product through one of its authorized service centers. All repairs for which warranty claims are made must be preauthorized by ICON. If the product is shipped to a service center, freight charges to and from the service center will be the customer's responsibility. For replacement parts shipped while the product is under warranty, the customer will be responsible for a minimal handling charge. For in-home service, the customer will be responsible for a minimal trip charge. This warranty does not extend to any damage to a product caused by or attributable to freight damage, abuse, misuse, improper or abnormal usage, or repairs not provided by an ICON authorized service center; to products used for commercial or rental purposes or as store display models; or to products transported or purchased outside the US. No other warranty beyond that specifically set forth above is authorized by ICON.

ICON is not responsible or liable for indirect, special, or consequential damages arising out of or in connection with the use or performance of the product; damages with respect to any economic loss, loss of property, loss of revenues or profits, loss of enjoyment or use, or costs of removal or installation; or other consequential damages of whatsoever nature. Some states do not allow the exclusion or limitation of incidental or consequential damages. Accordingly, the above limitation may not apply to you.

The warranty extended hereunder is in lieu of any and all other warranties, and any implied warranties of merchantability or fitness for a particular purpose are limited in their scope and duration to the terms set forth herein. Some states do not allow limitations on how long an implied warranty lasts. Accordingly, the above limitation may not apply to you.

This warranty gives you specific legal rights. You may also have other rights that vary from state to state.

ICON Health & Fitness, Inc., 1500 S. 1000 W., Logan, UT 84321-9813

